

APPLICATIONS

Fracturing Reversed Tone
Photonic Crystals

Is there a solution to optimize fracturing?

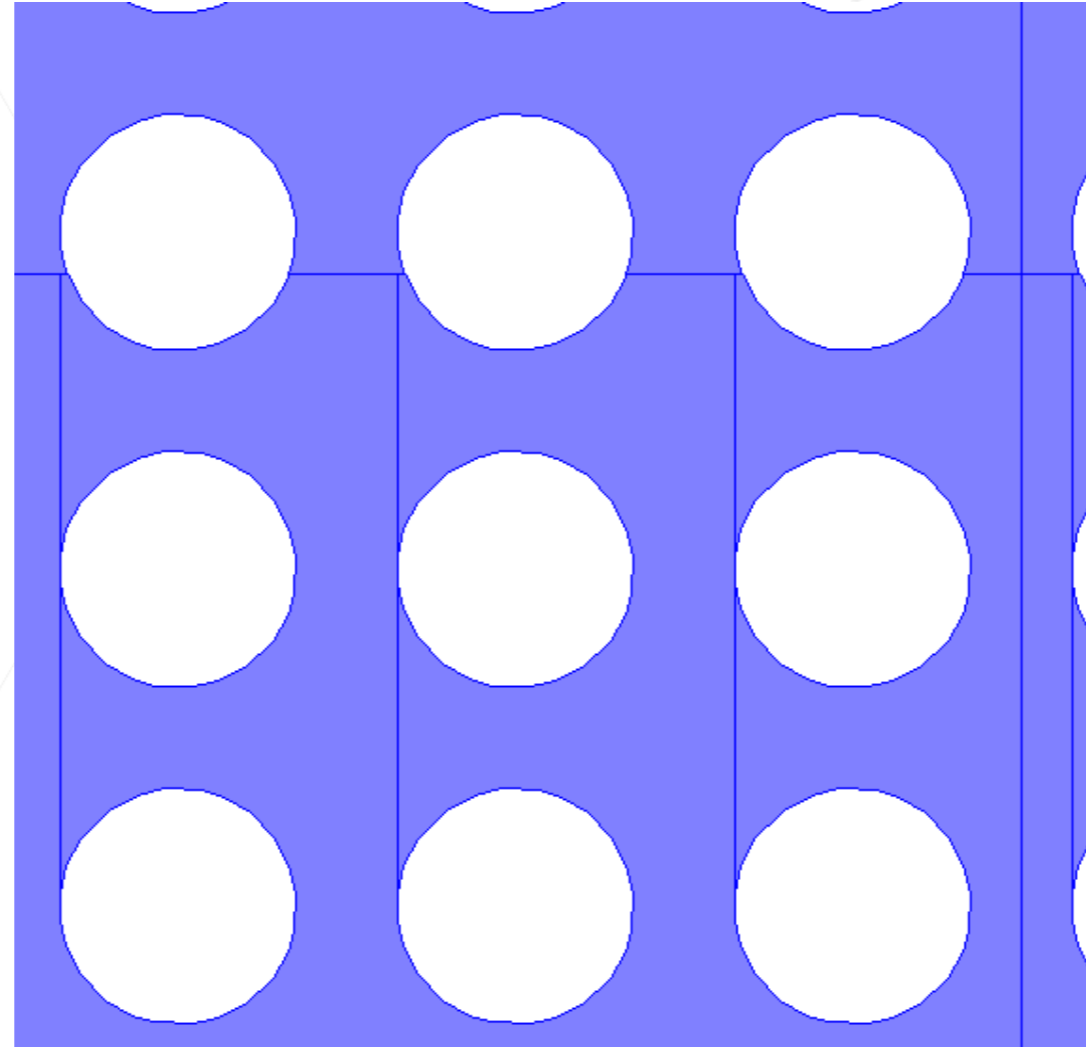

In a flattened design, cuts influence non-uniform fracturing.

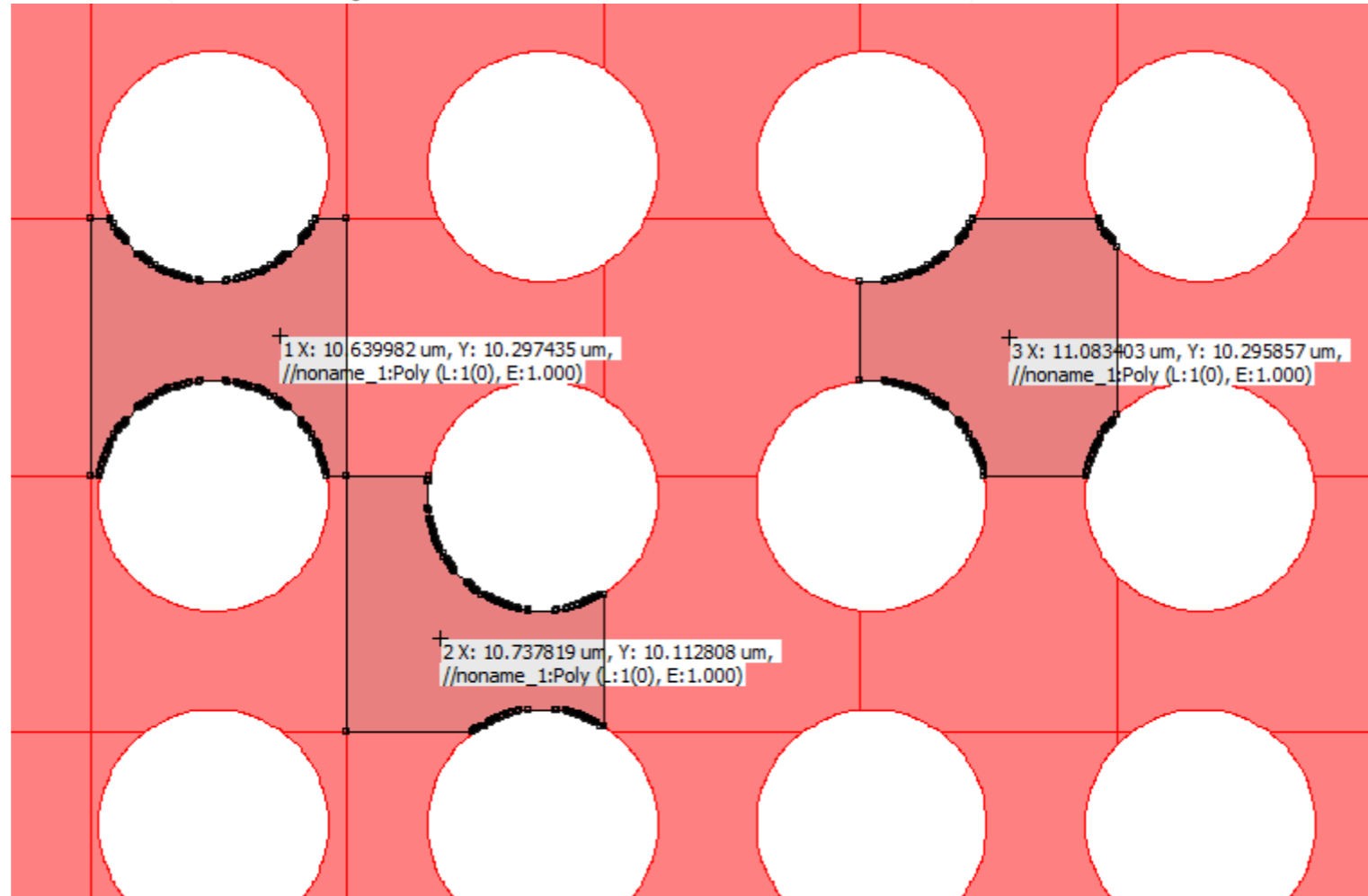

In a flattened design, cuts influence non-uniform fracturing.

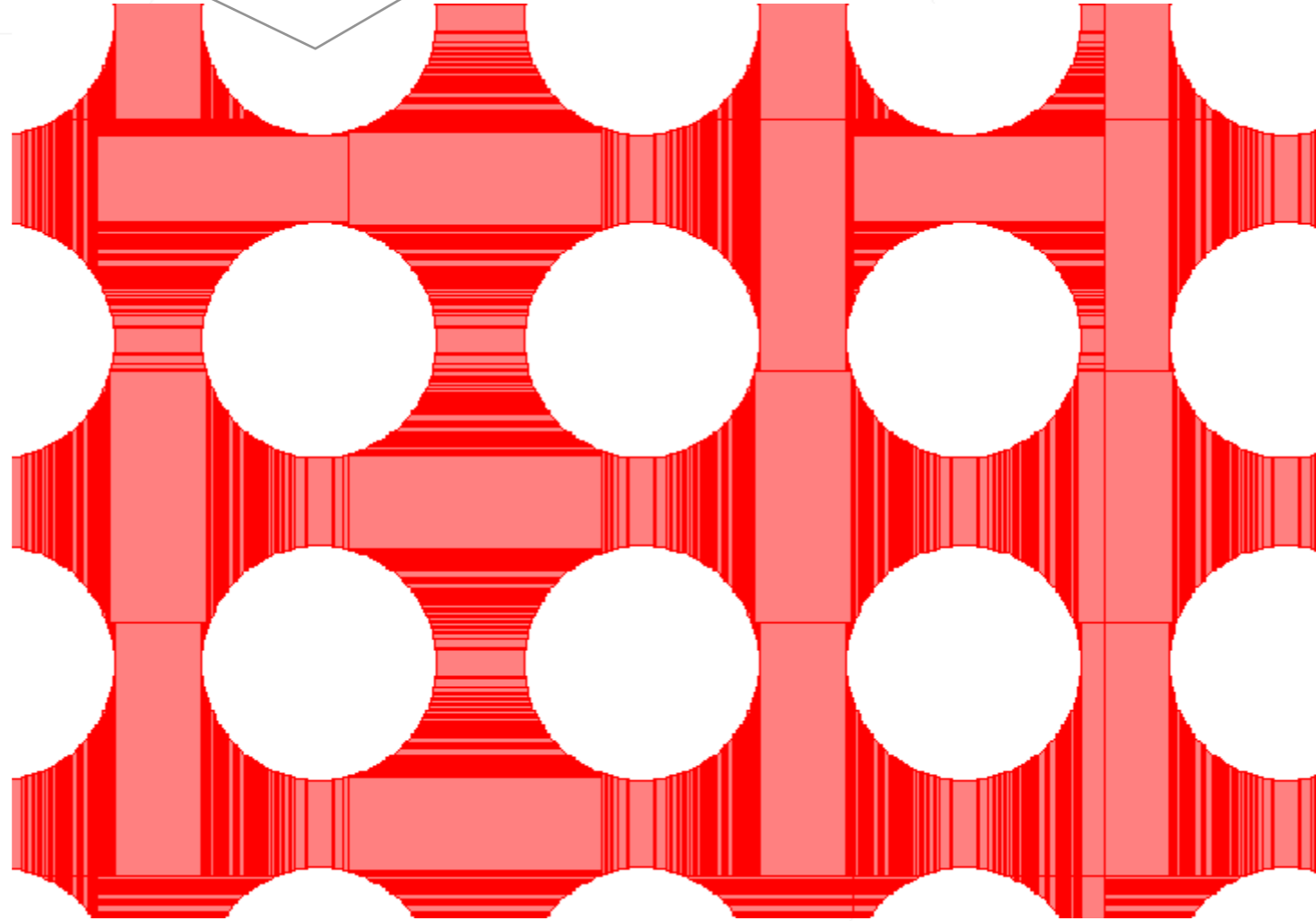

In a hierarchical design, cuts could influence more uniform fracturing.

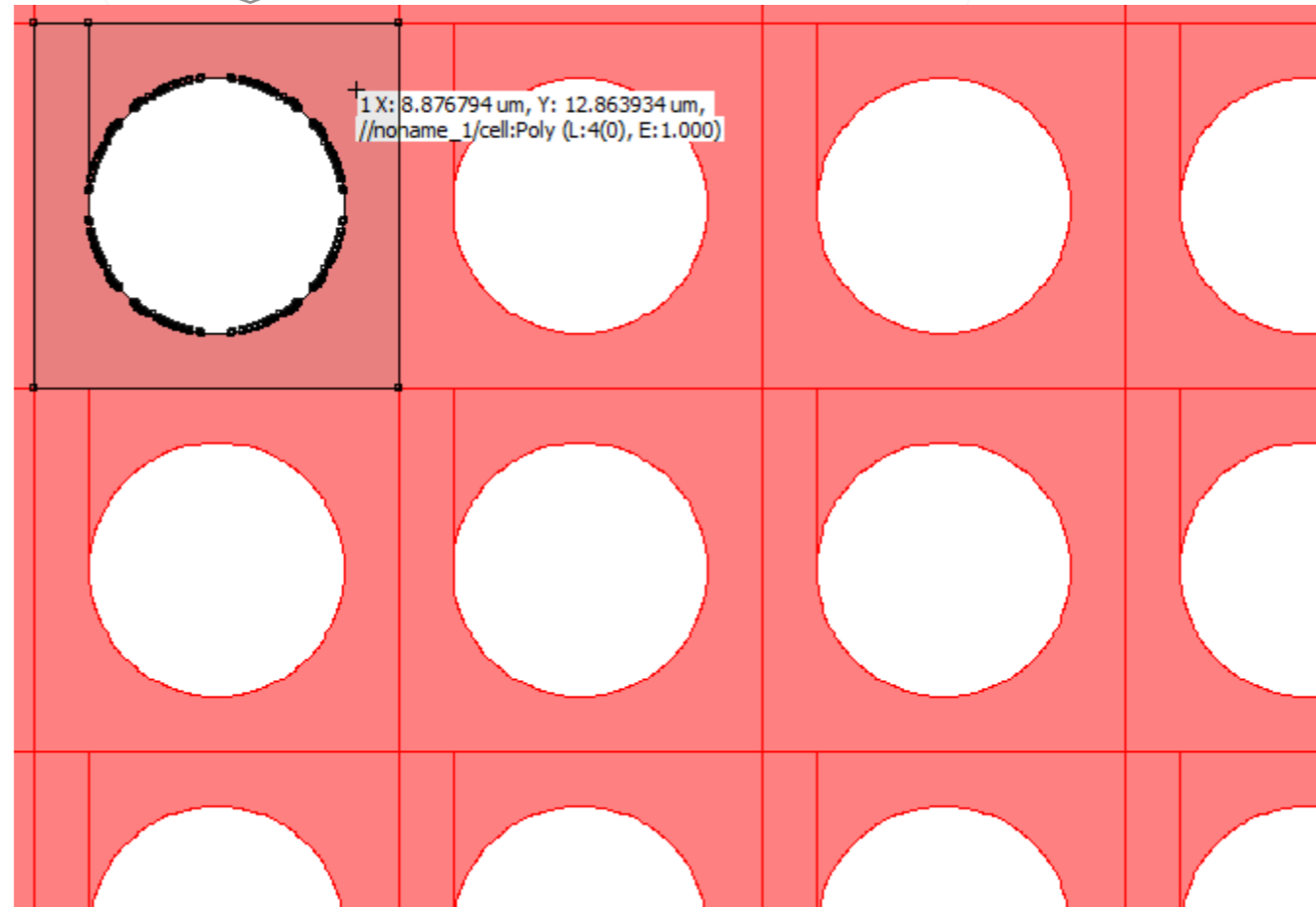

In a hierarchical design, cuts influence more uniform fracturing; however slivers can occur.

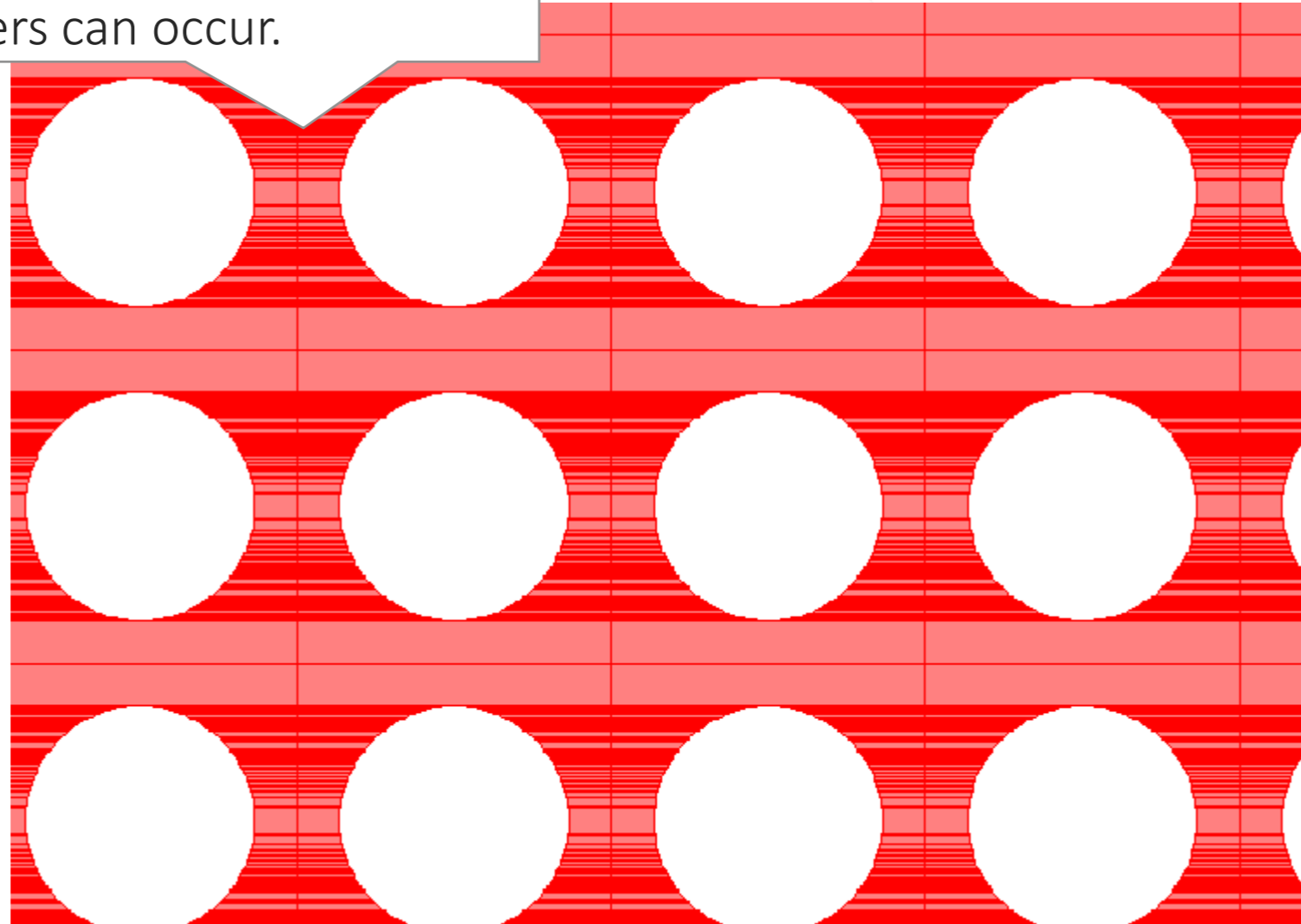

Caveats of Both Options

- Limitation of the designers ability to plan for data-prep to machine format.
- Number of vertices for curve digitization can be arbitrary:
 - Too many vertices influences the creation of too many shapes.
 - Too many vertices can increase the fracturing computation time.

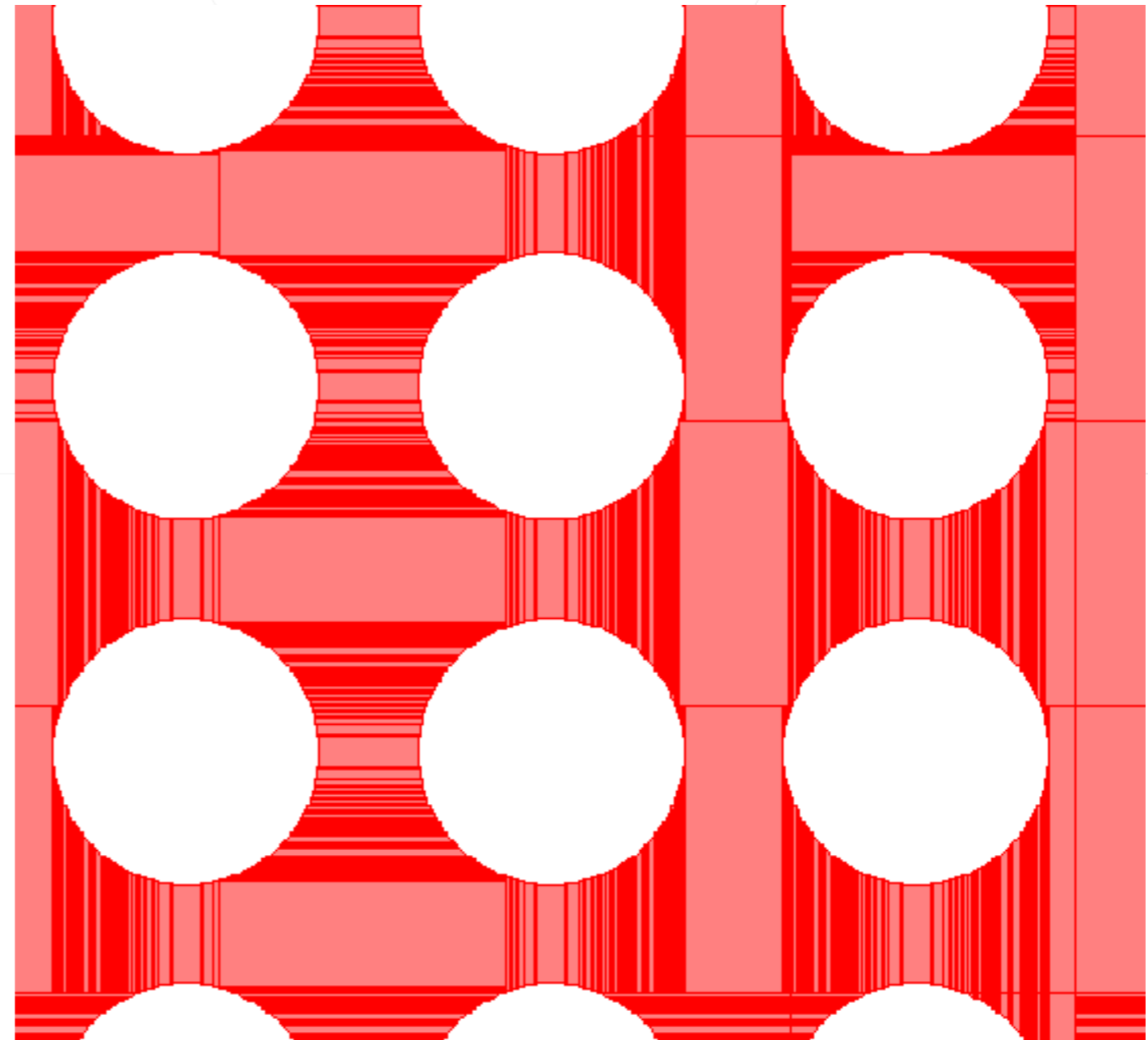

Use Curved Fracturing to optimize the final fracture:

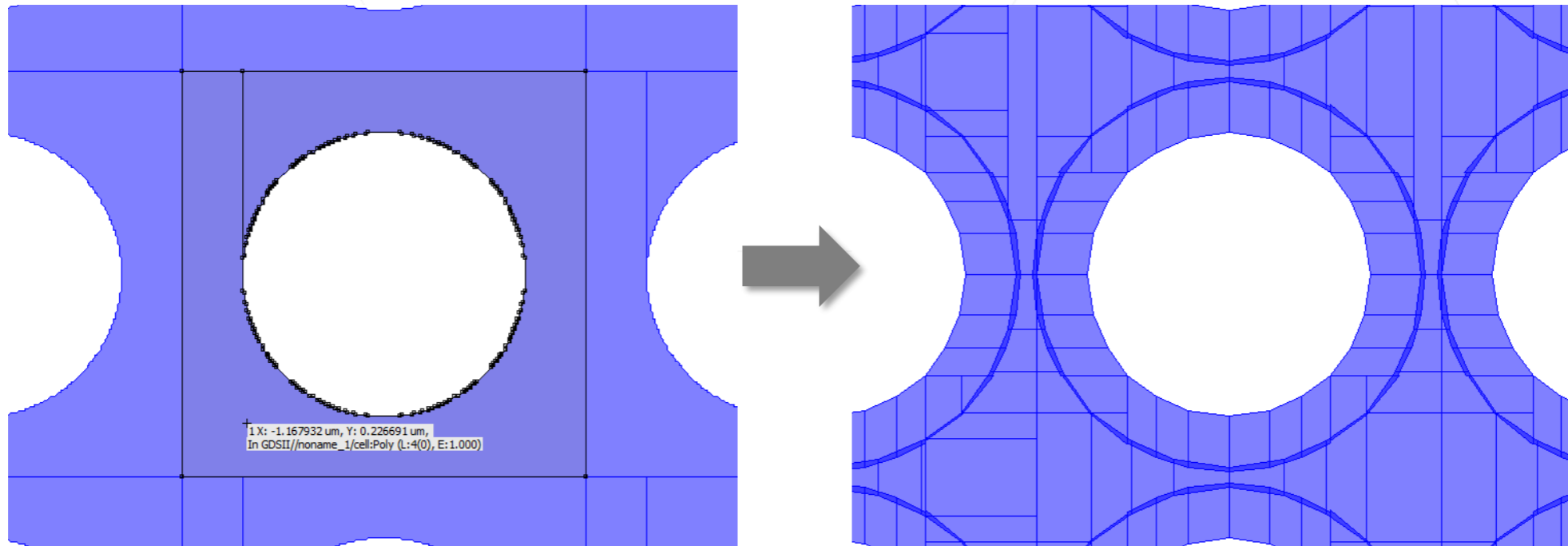

How is this done? ...

Step 1: Reduce Vertices

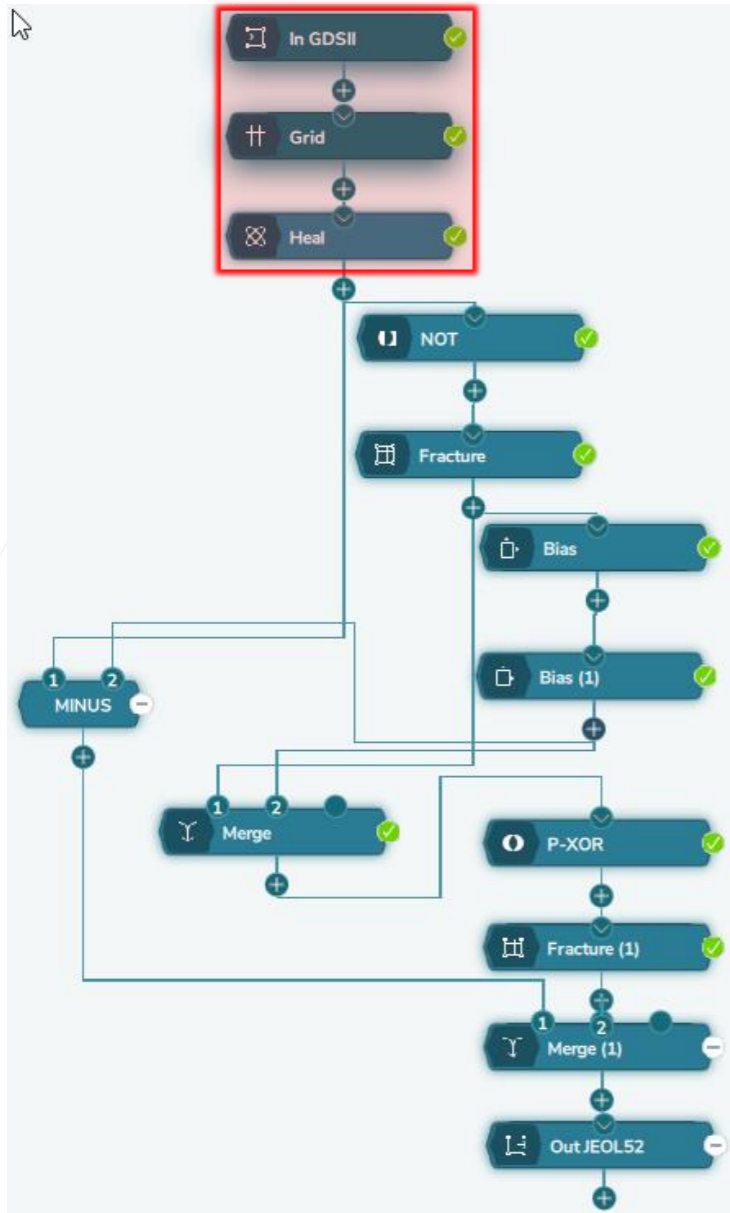

- Import the file
- Reduce the number of vertices to reduce computation time downstream
- Heal the pattern for any overlaps

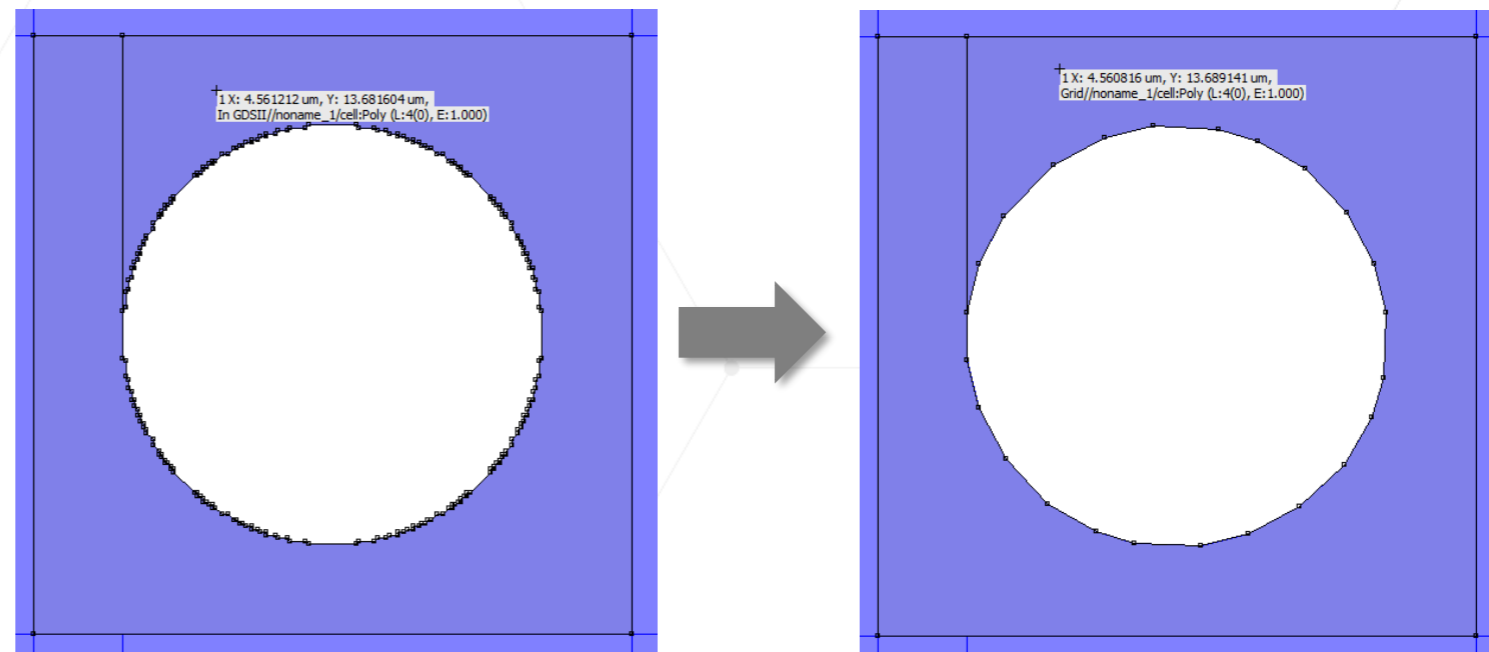

Step 2: Create Perfect Circles

- Reverse tone the pattern
- Re-align vertices

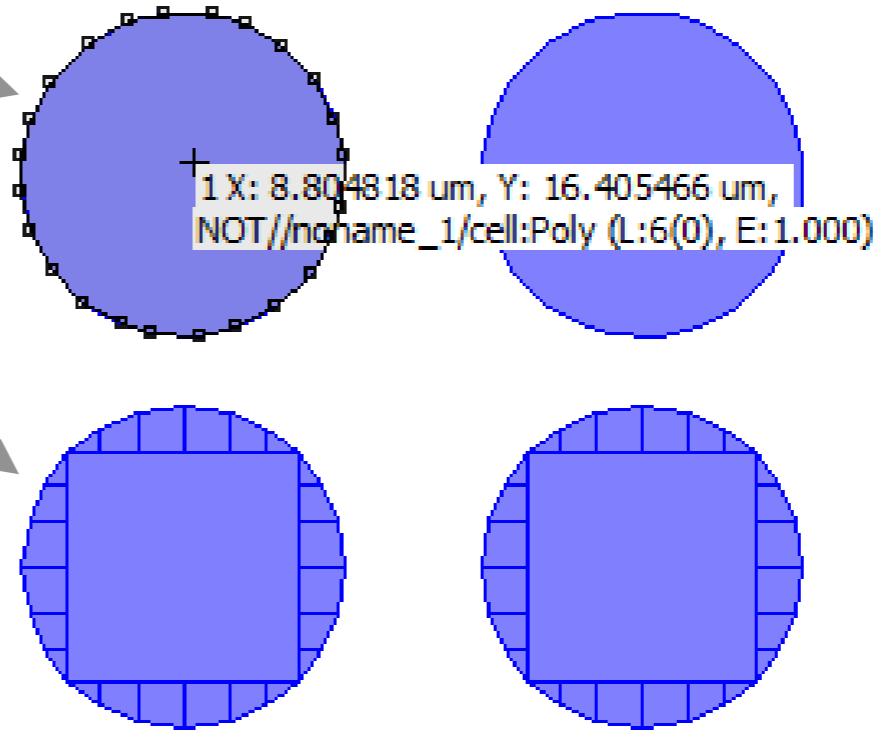
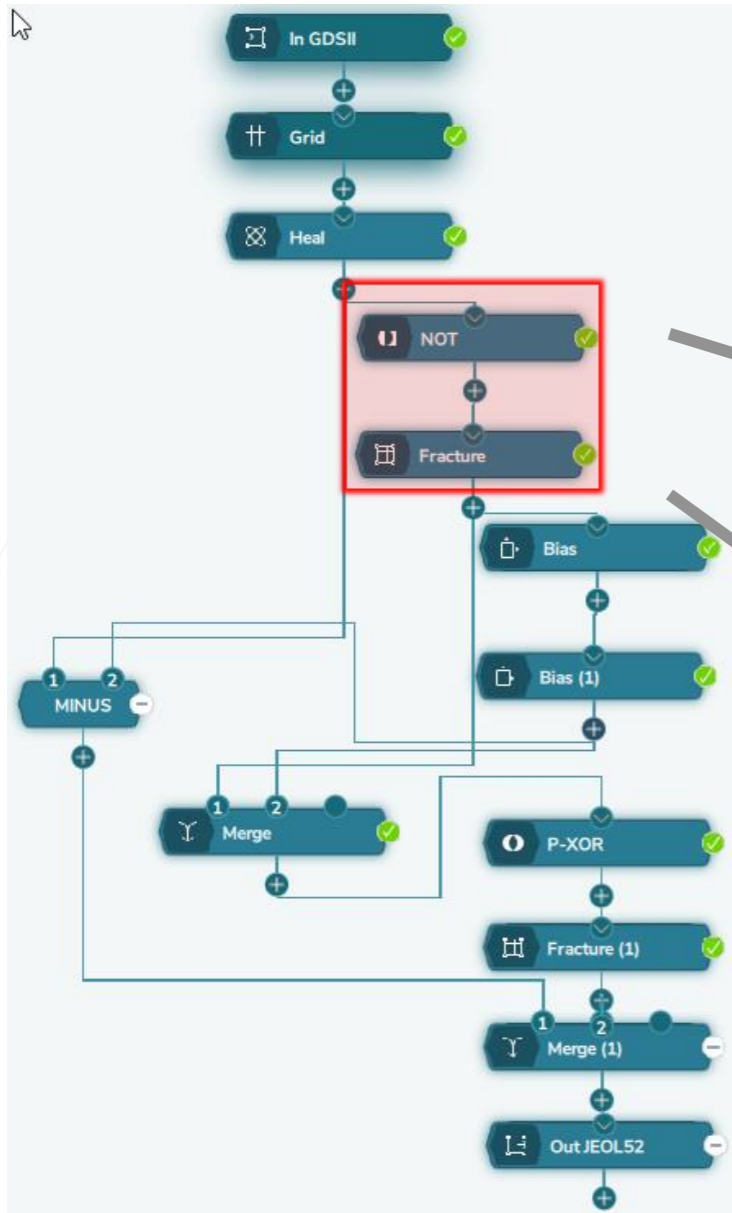

Step 3: Make Room for Rings

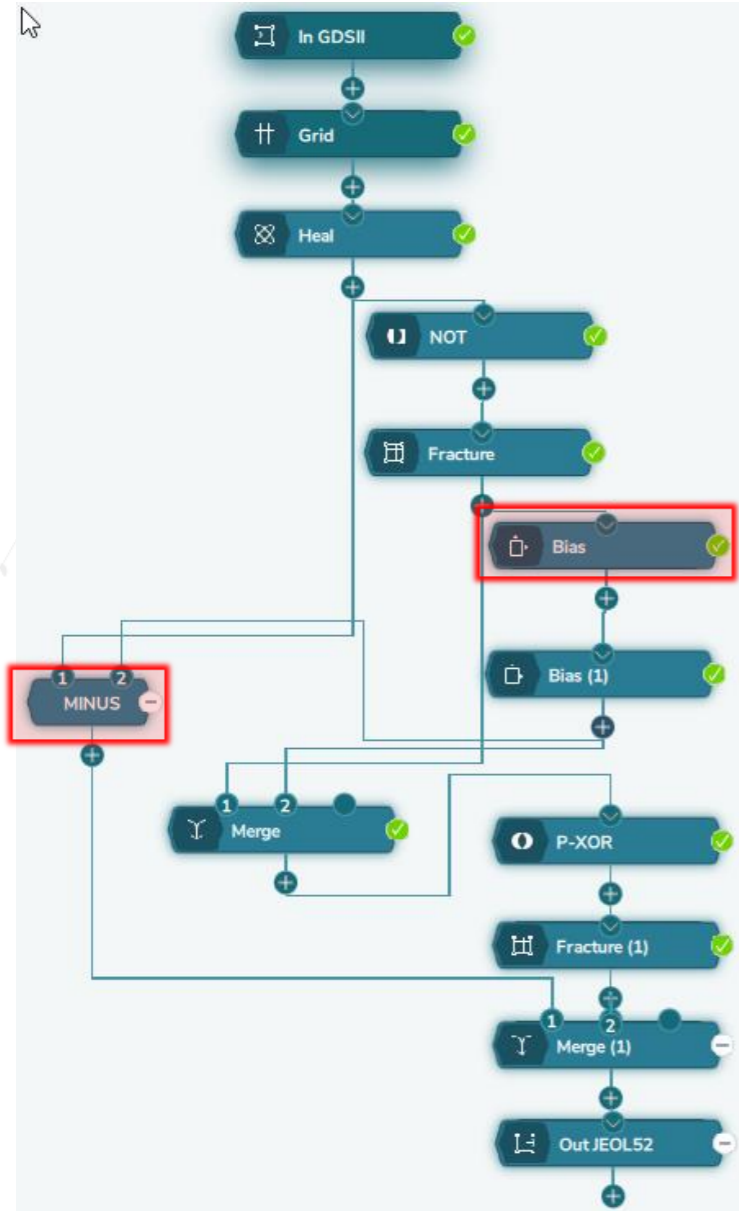

- Bias the circles larger (grey). The bias determines the width of the rings.
- Create room for the rings by subtracting the biased circles from the original pattern.

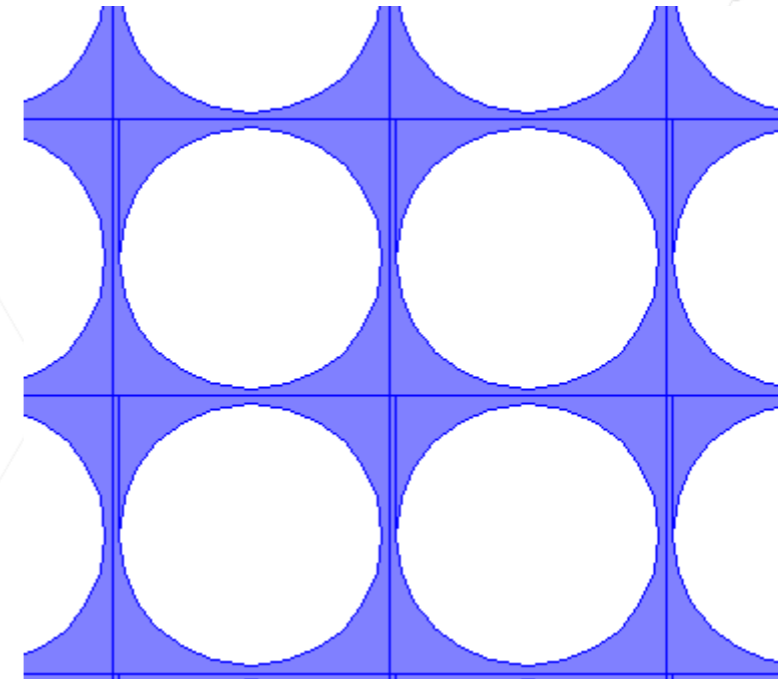
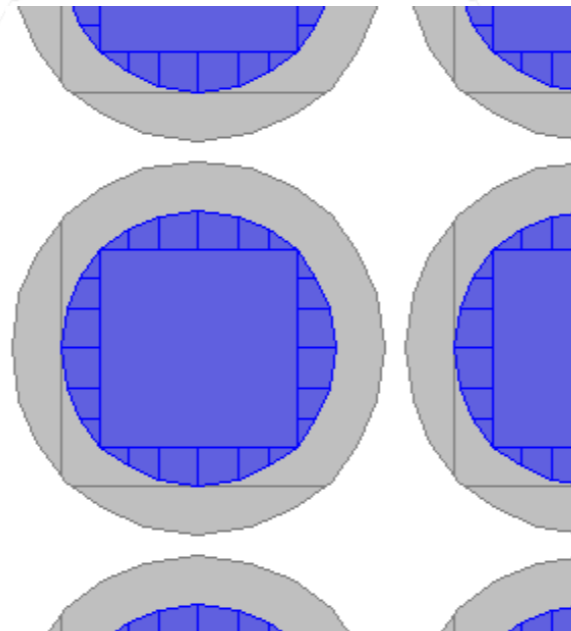

Step 4: Create the Rings

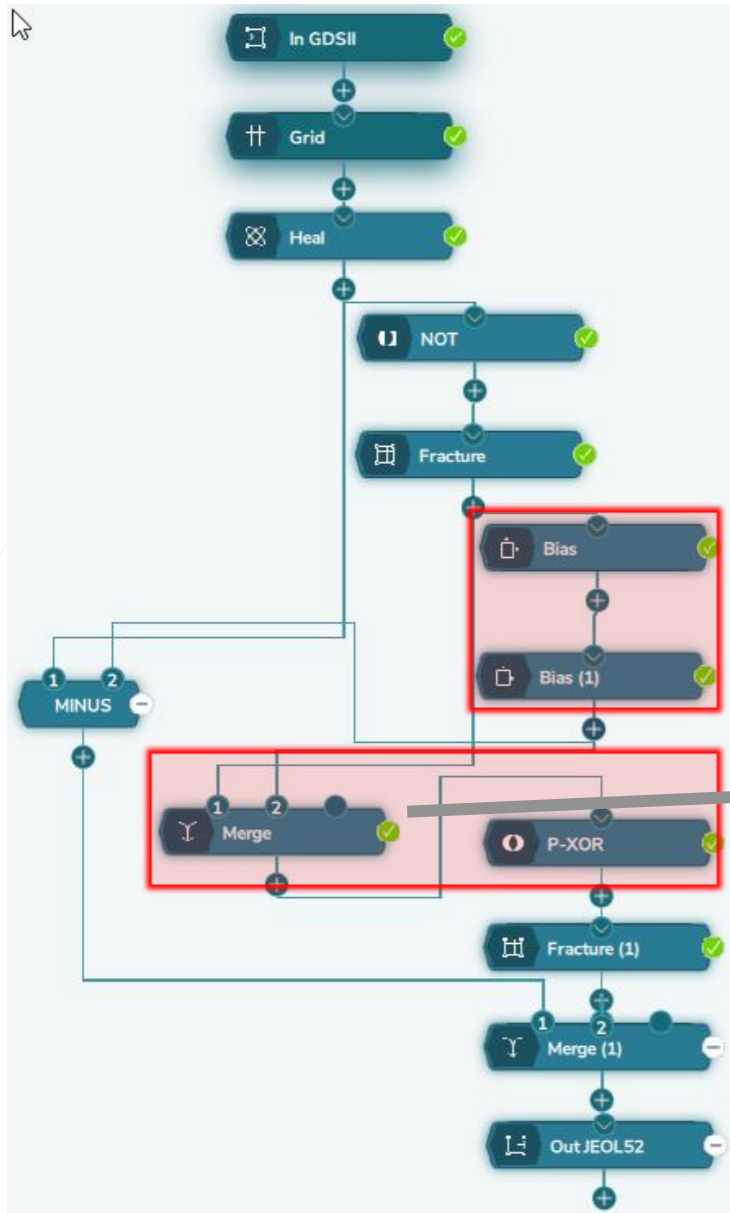

- Add a 2 nm bias to create a small overlap for the last merge
- Merge the fractured circles with the larger circles and create rings with a P-XOR

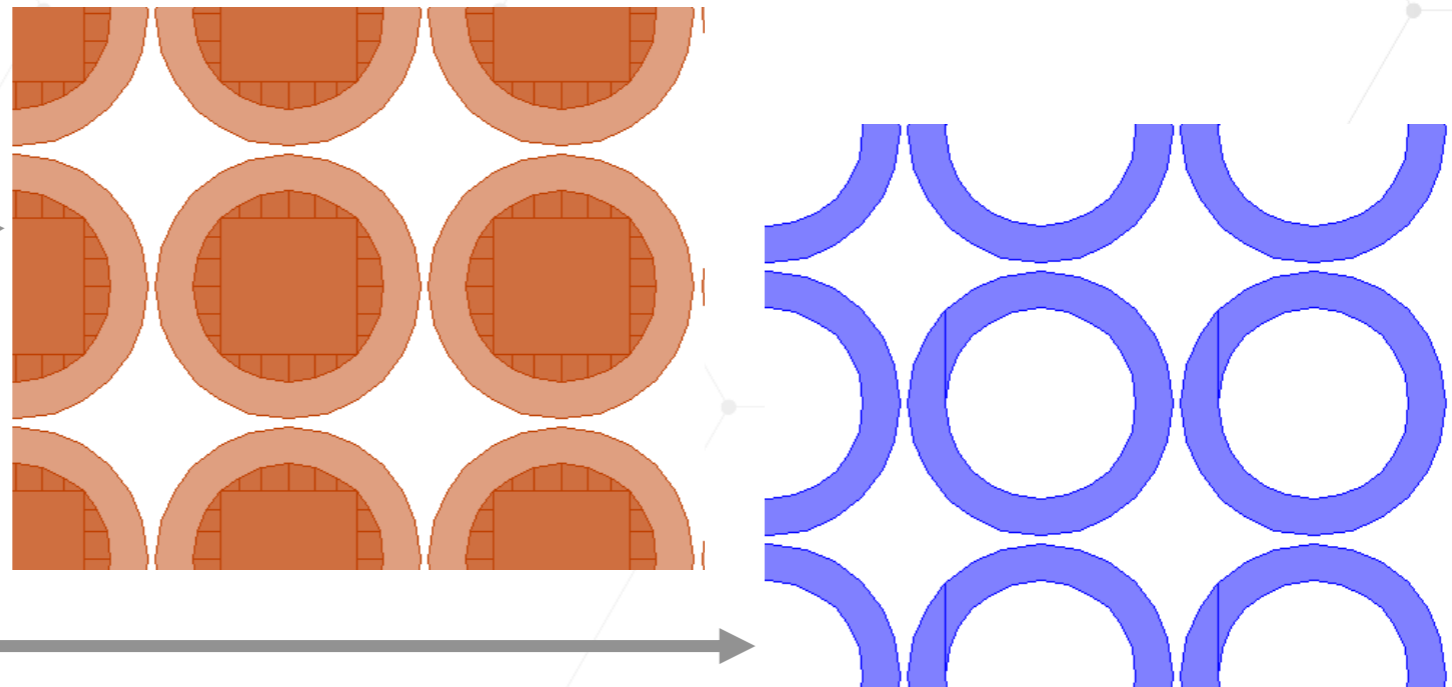

- Fracture the rings with Curved Fracturing and merge it all together.

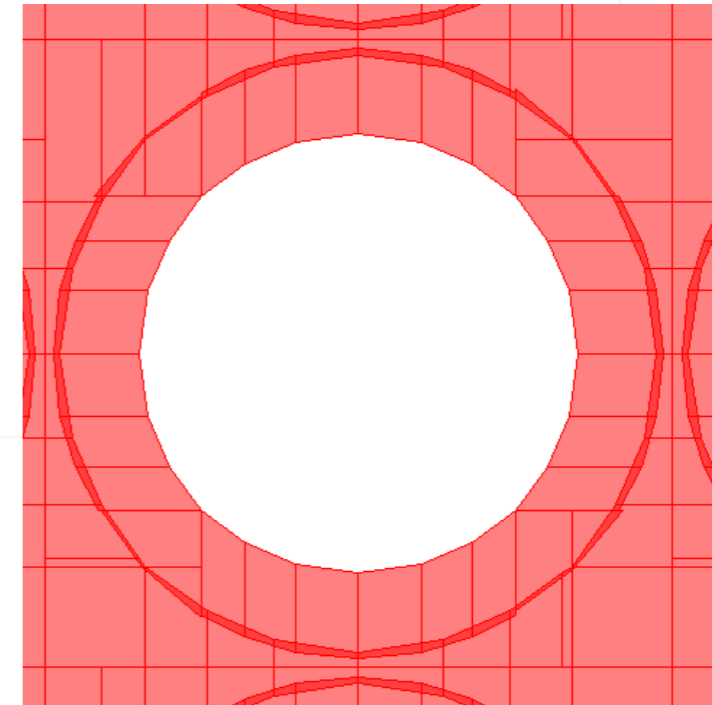
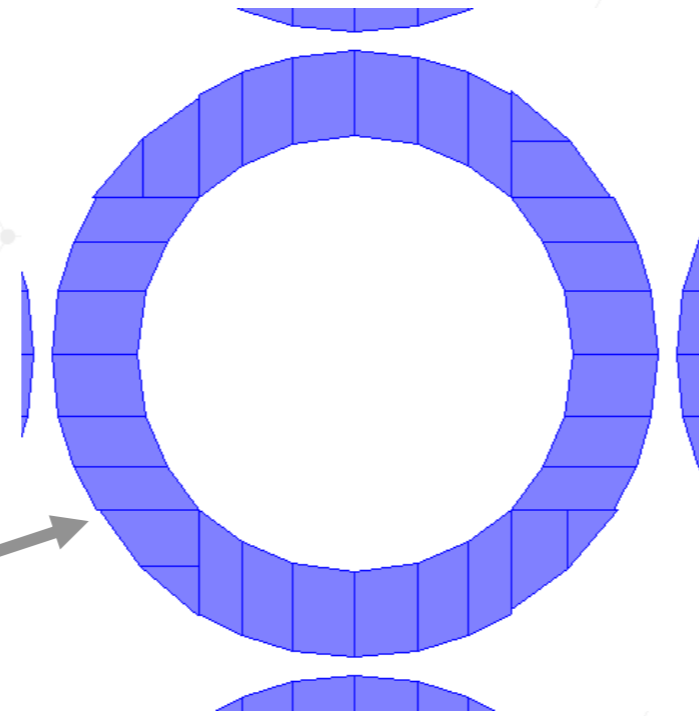
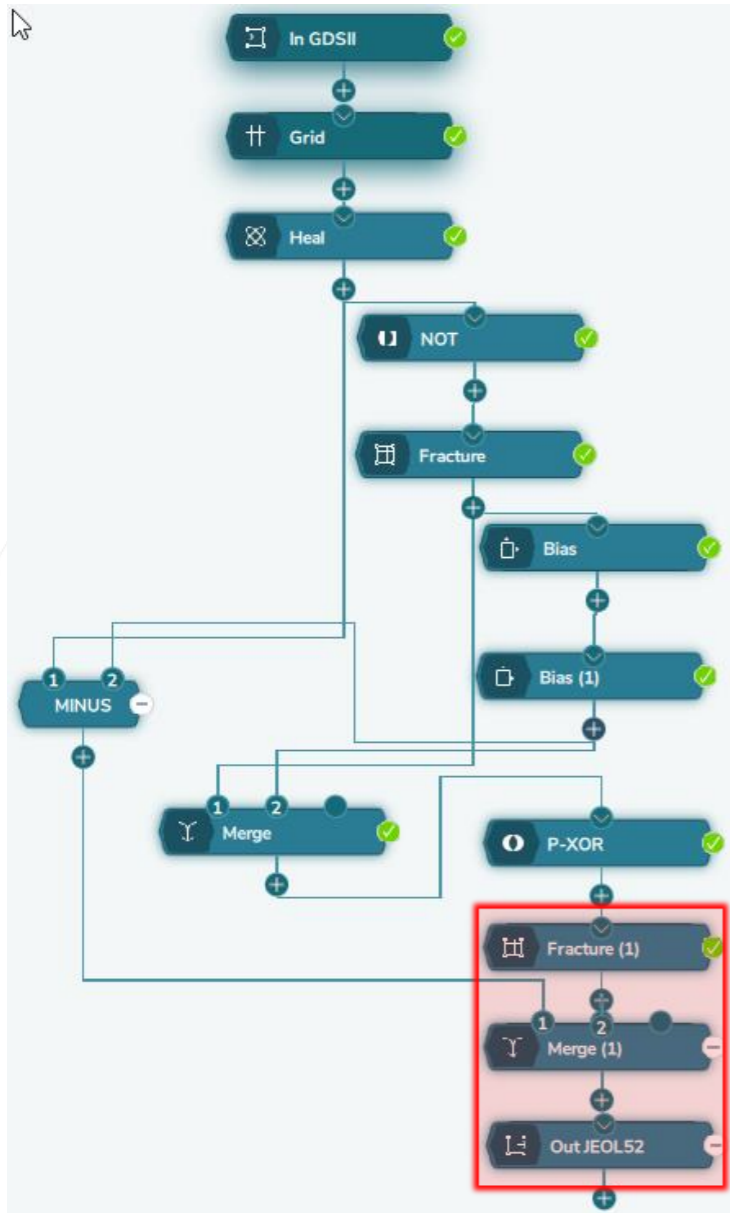

Alternative Solution

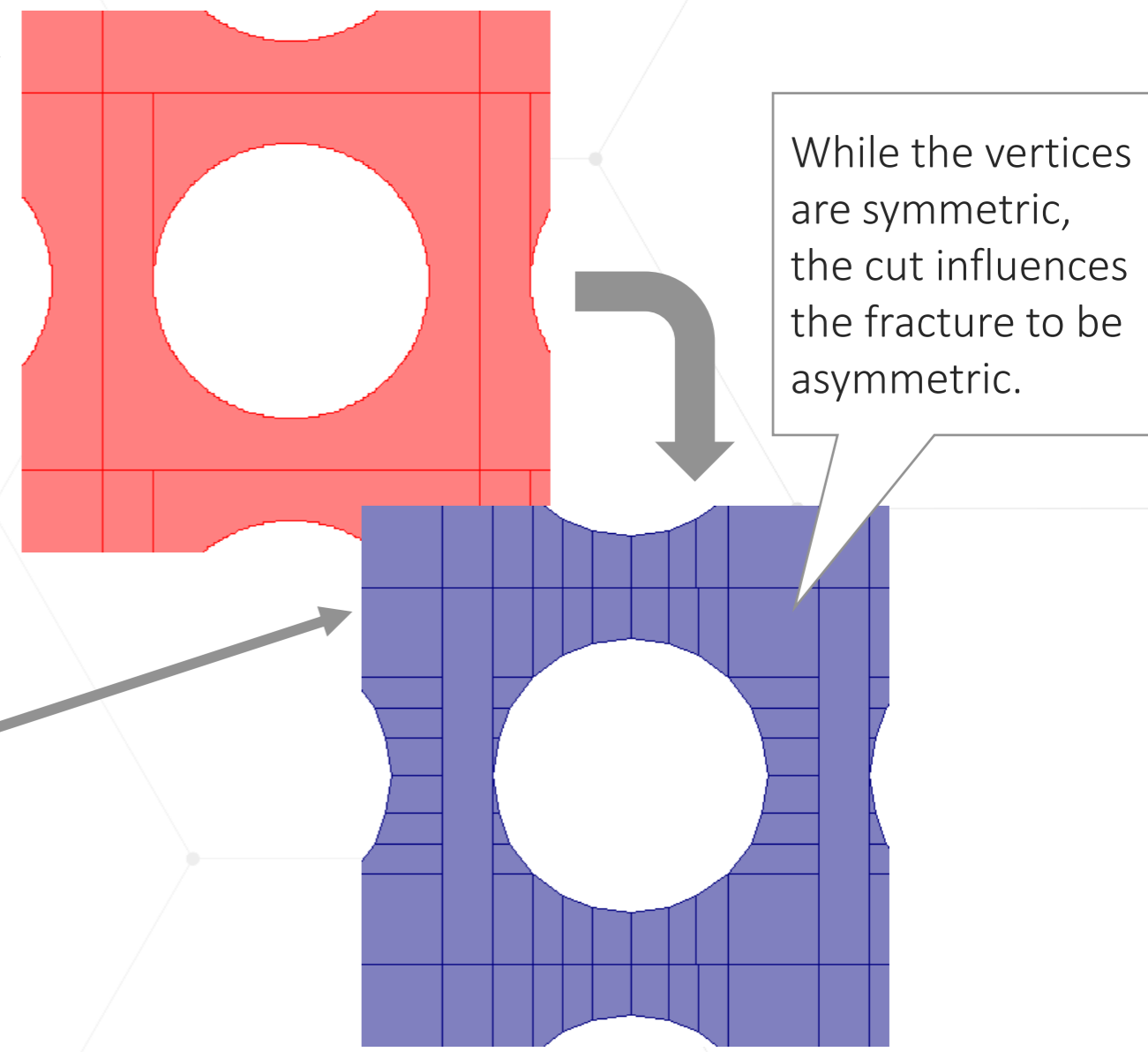
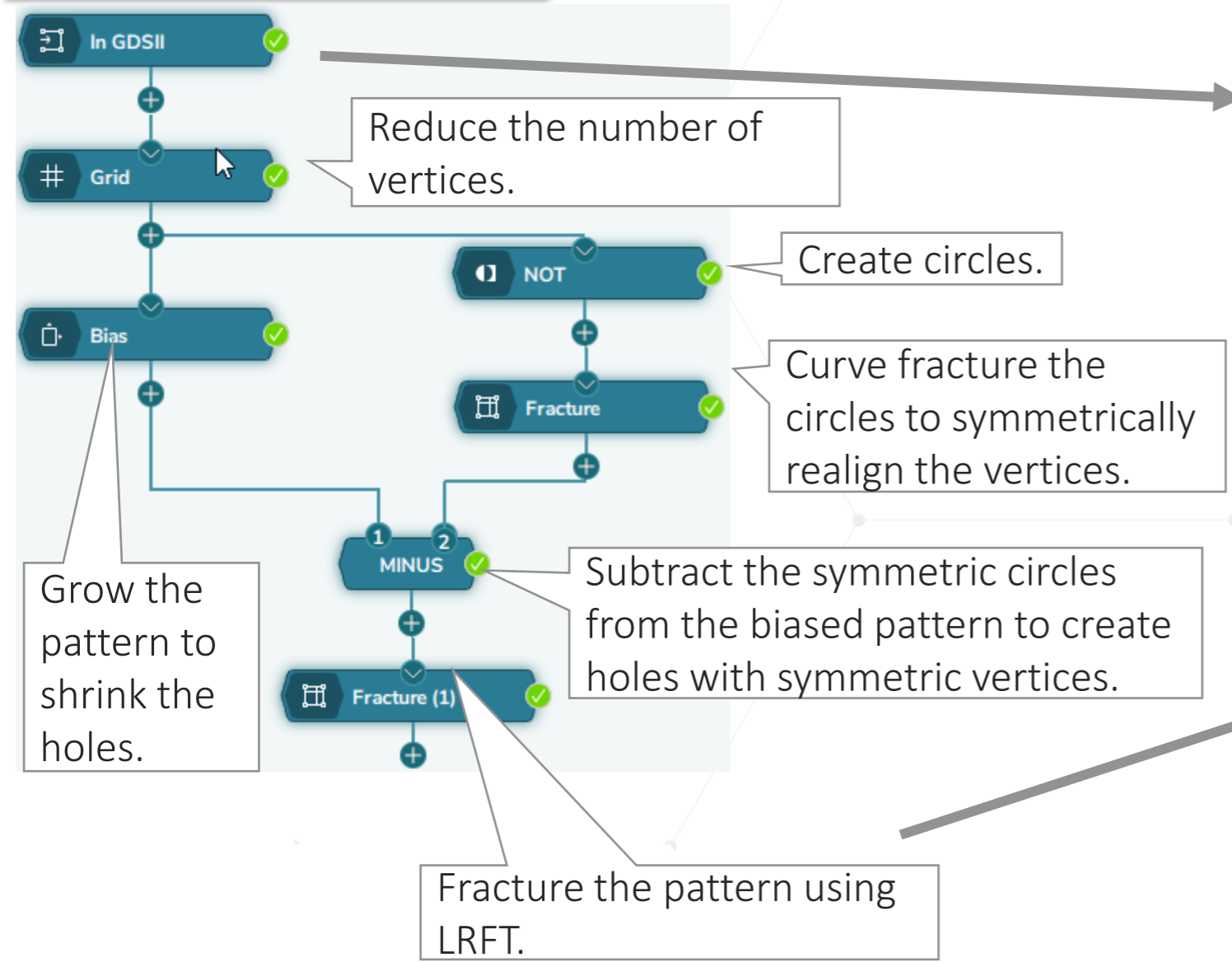

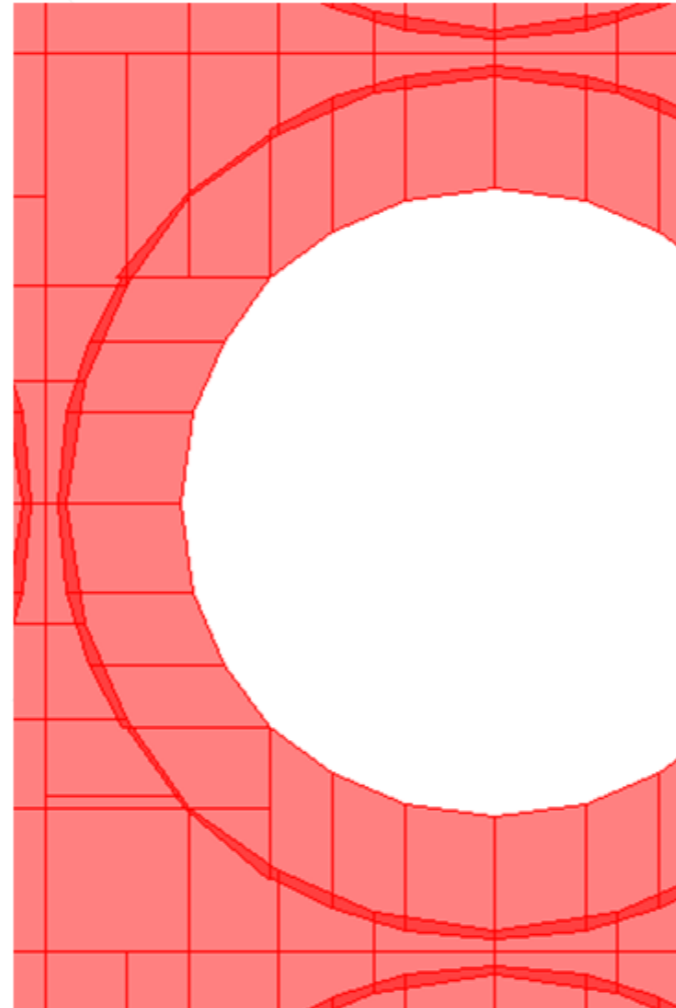
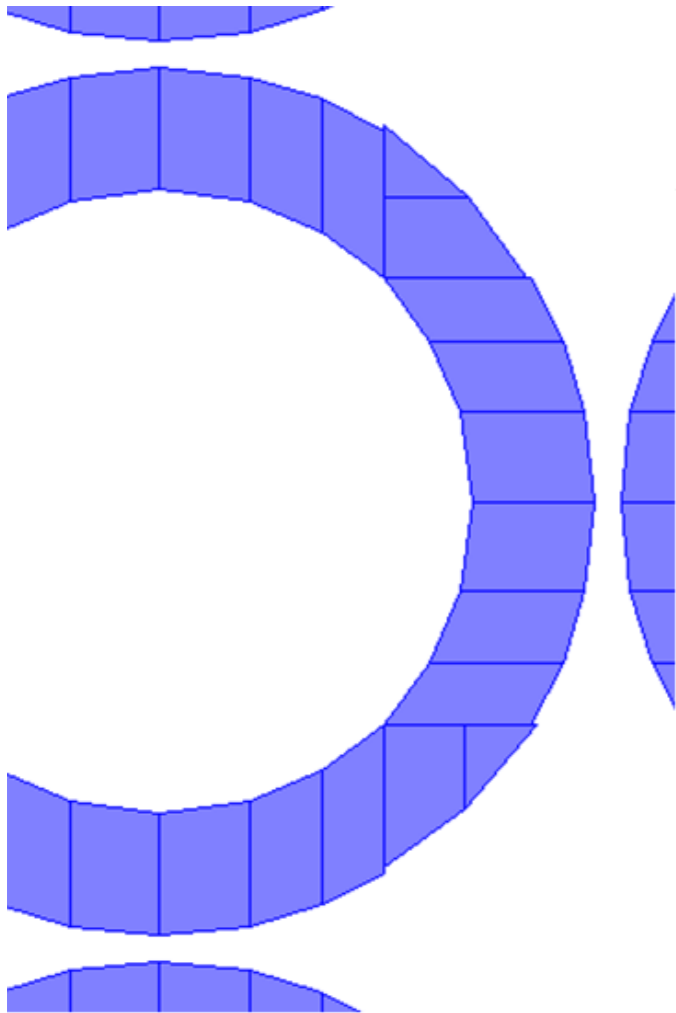

- The idea is to decouple vertices from adjacent features to help optimize the fracture.
- Applied Technologies:
 - Grid: Layout Smoothing Tolerance
 - P-XOR
 - Curved Fracturing
- Curved fracturing works for photonic crystals
 - Positive tone
 - Negative tone
- Solution is independent of the design whether it is hierarchical or flattened
- Because Curved fracturing is unique to BEAMER, this can only be done with BEAMER.

APPLICATIONS

Case Study:
University of California Santa Barbara

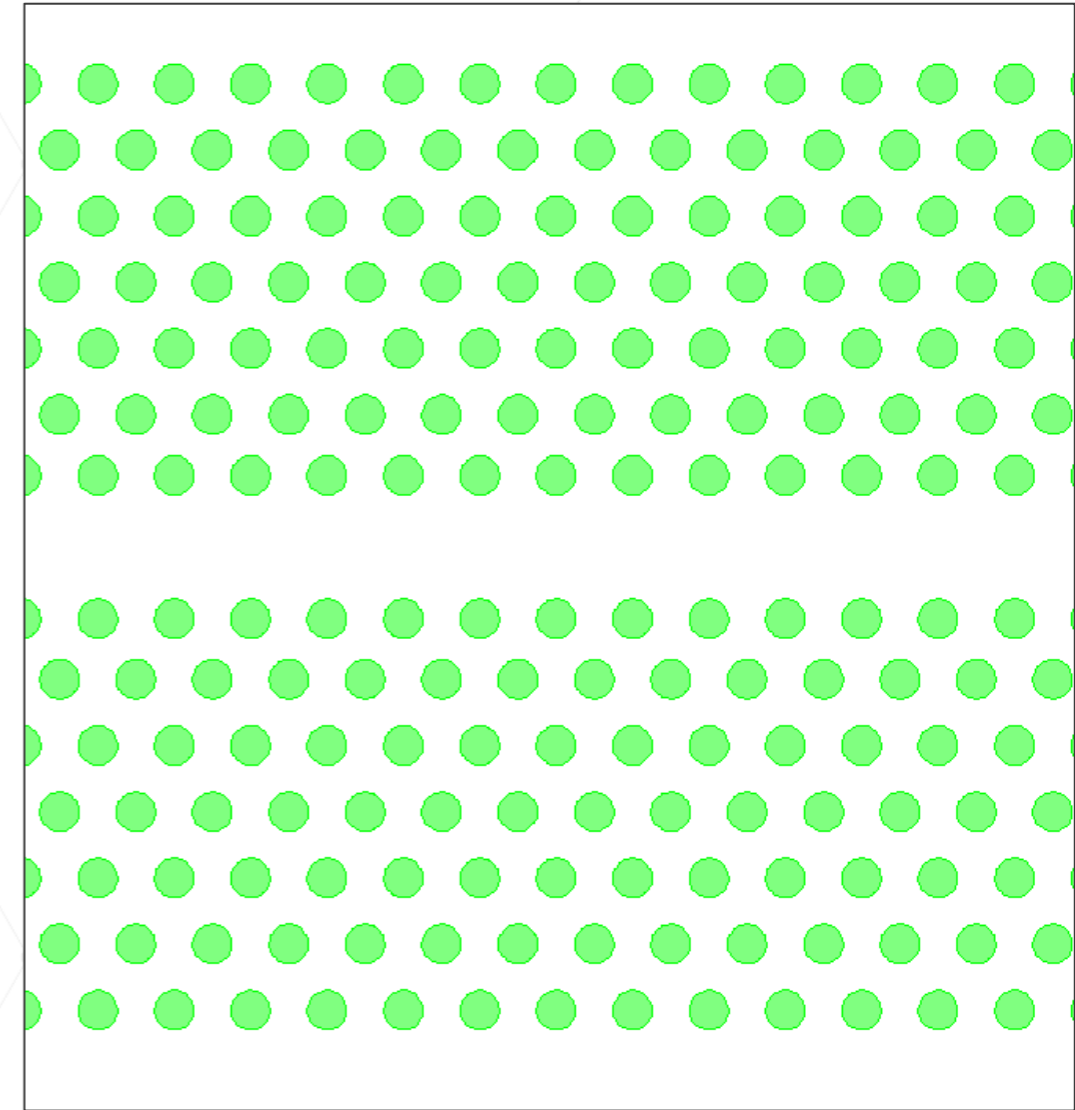
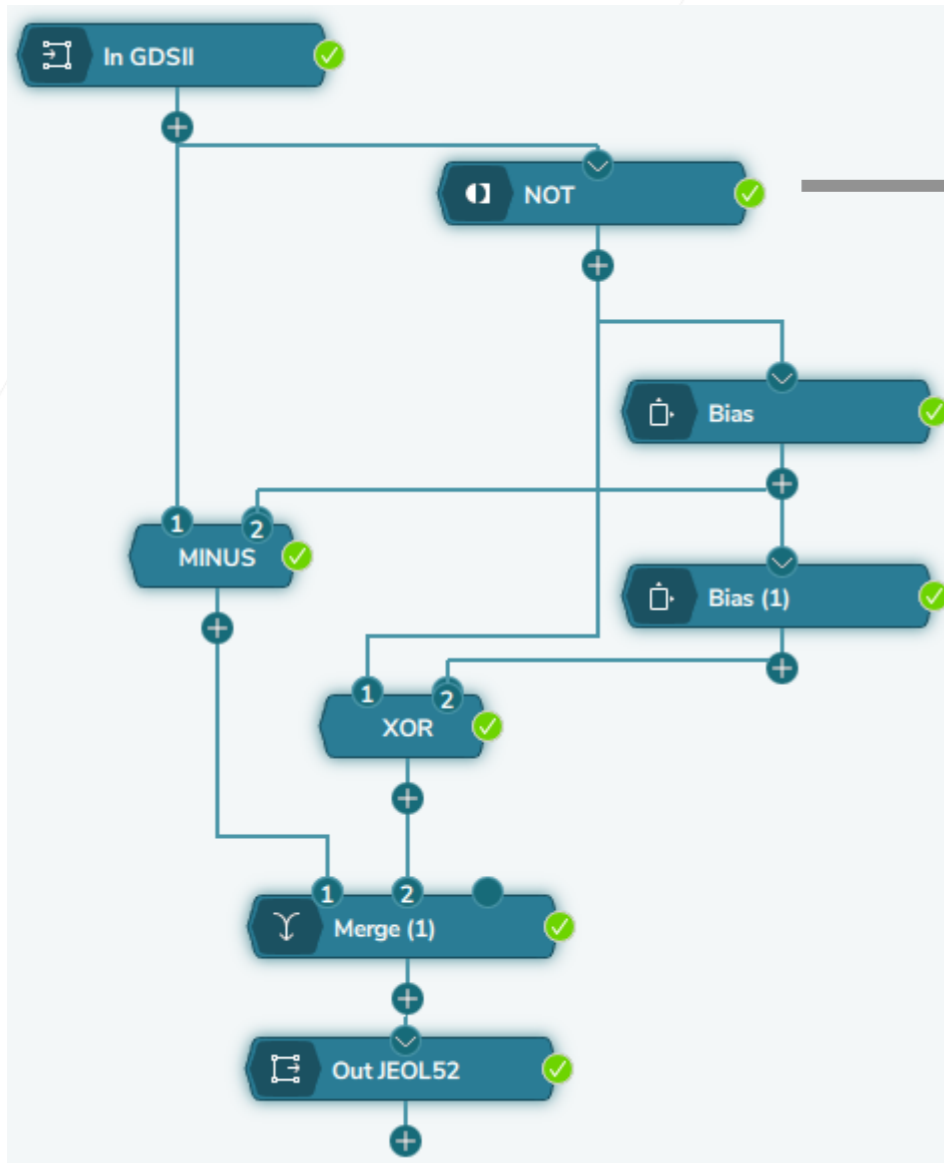

UCSB Application

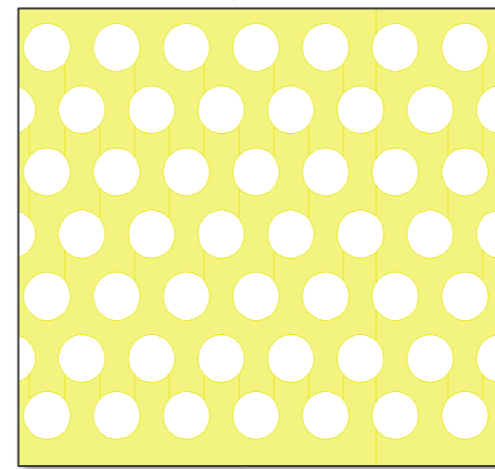
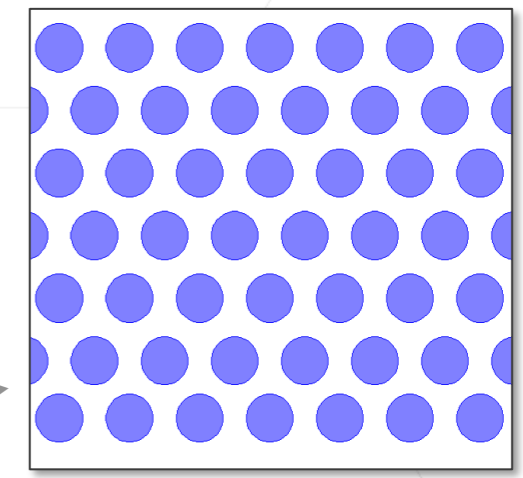
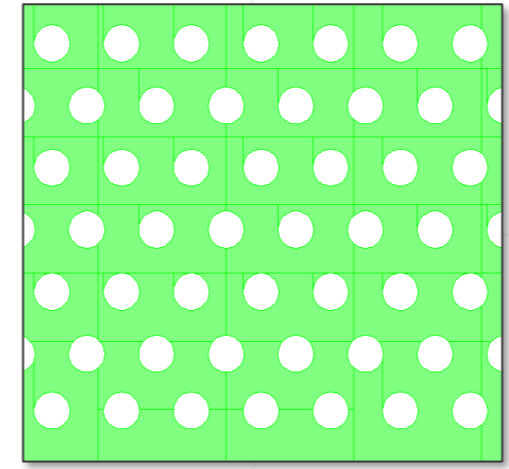
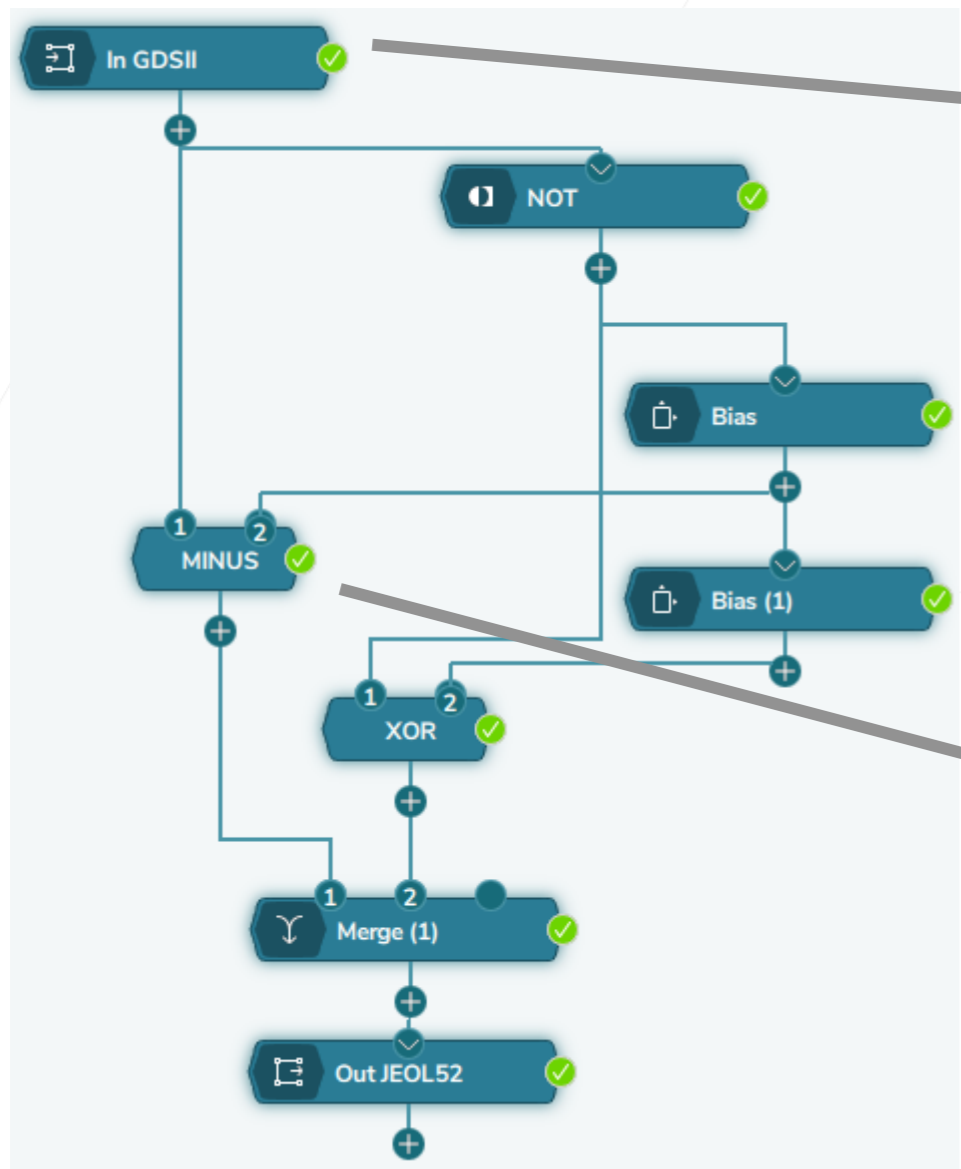

Green – Blue = Yellow
 Make the holes larger so that we can put the rings inside later with a little bit of overlap.

UCSB Application

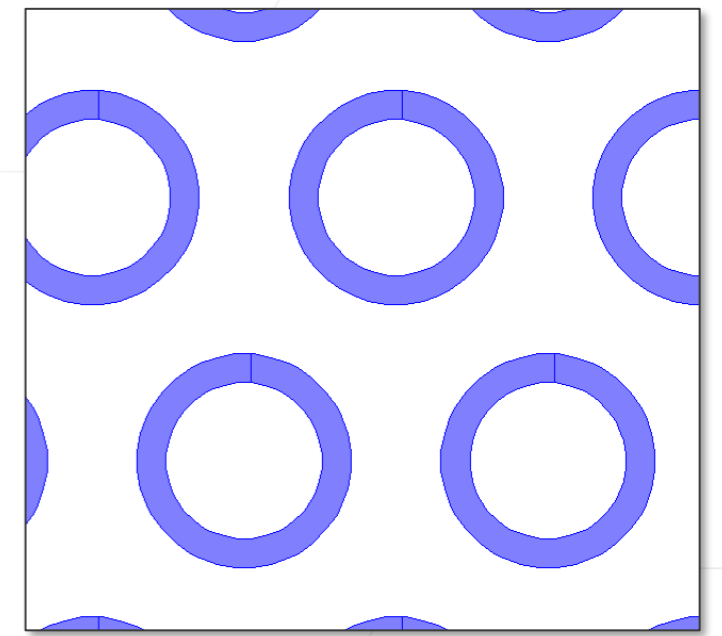
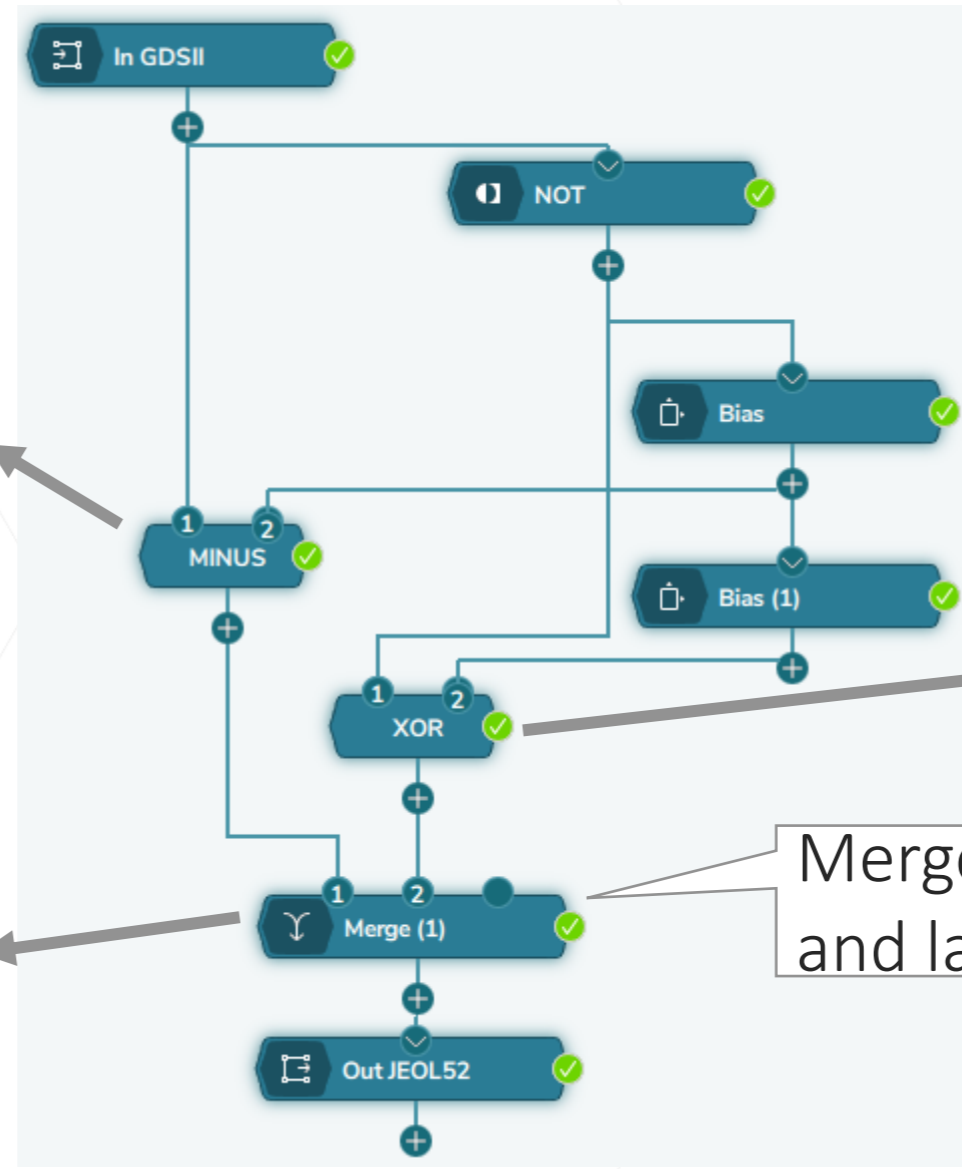
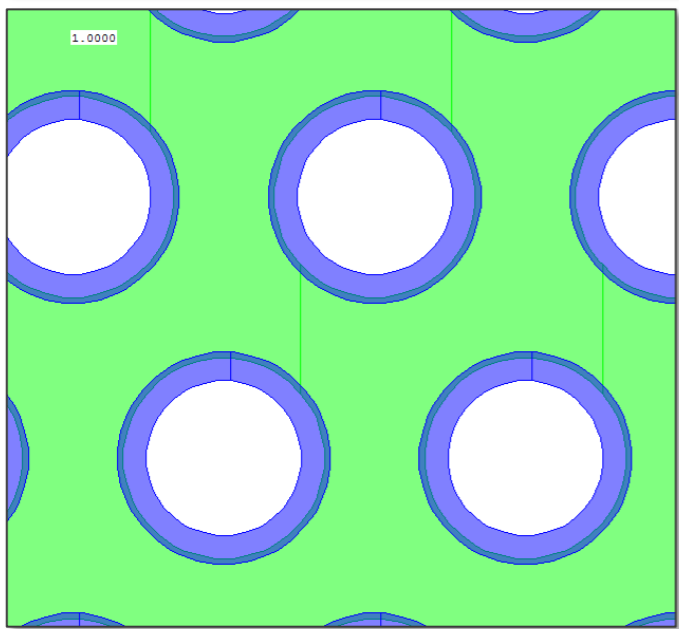
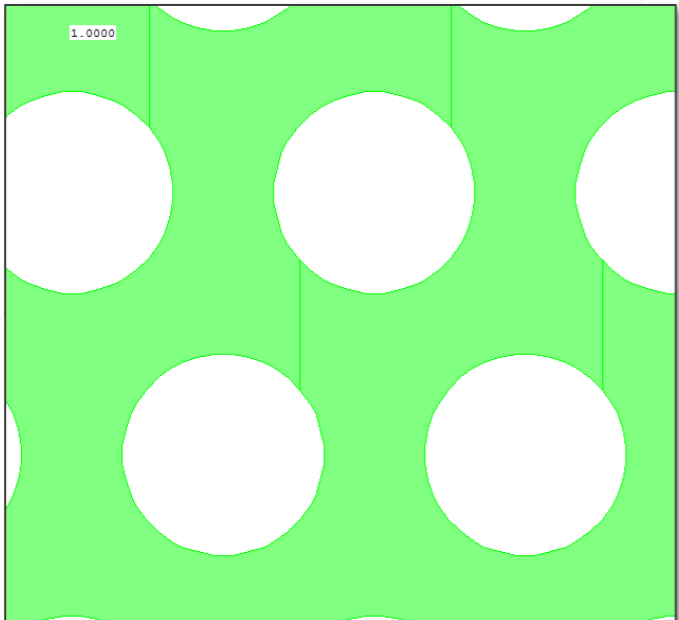

Merge together the rings and large hole pattern.

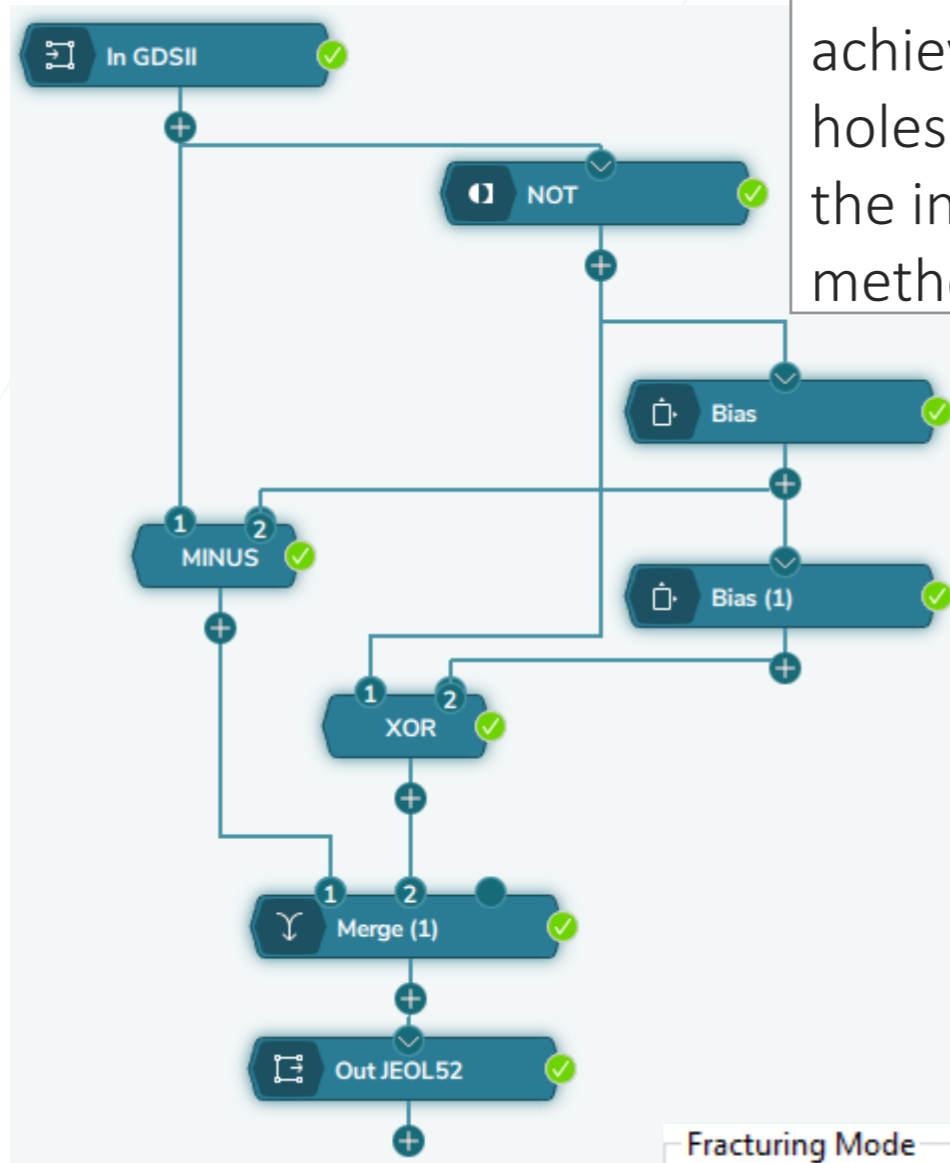

Fracture optimization achieved. Vertices for the holes are decoupled using the internal bordering method.

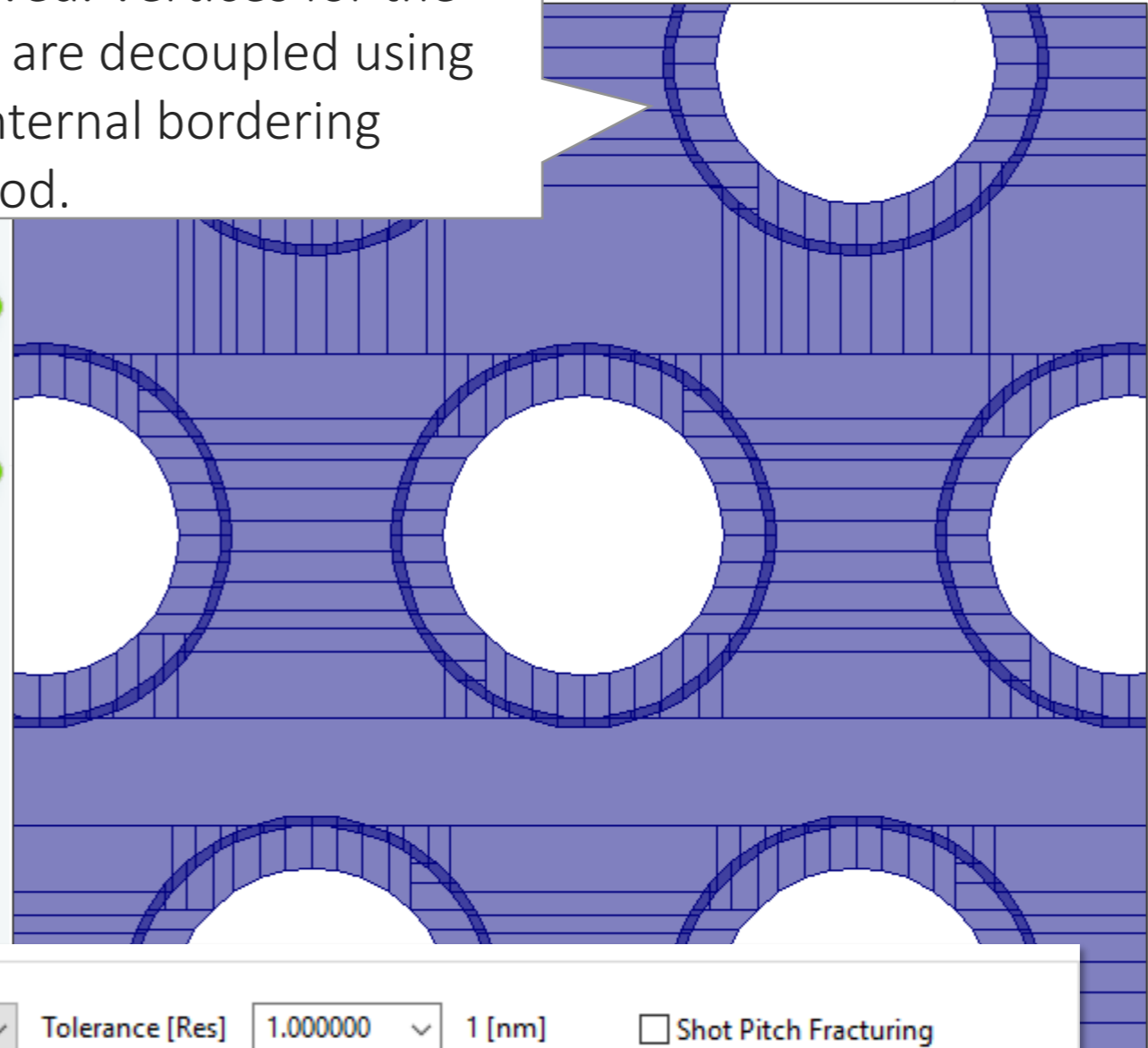

Fracturing Mode

Curved Tolerance [Res] 1.000000 1 [nm] Shot Pitch Fracturing

- Again, the idea is to decouple vertices from adjacent features to help optimize the fracture
- Applied Technologies:
 - Curved Fracturing
- Curved fracturing works for photonic crystals
 - Positive tone
 - Negative tone
- Solution is independent of the design whether it is hierarchical or flattened

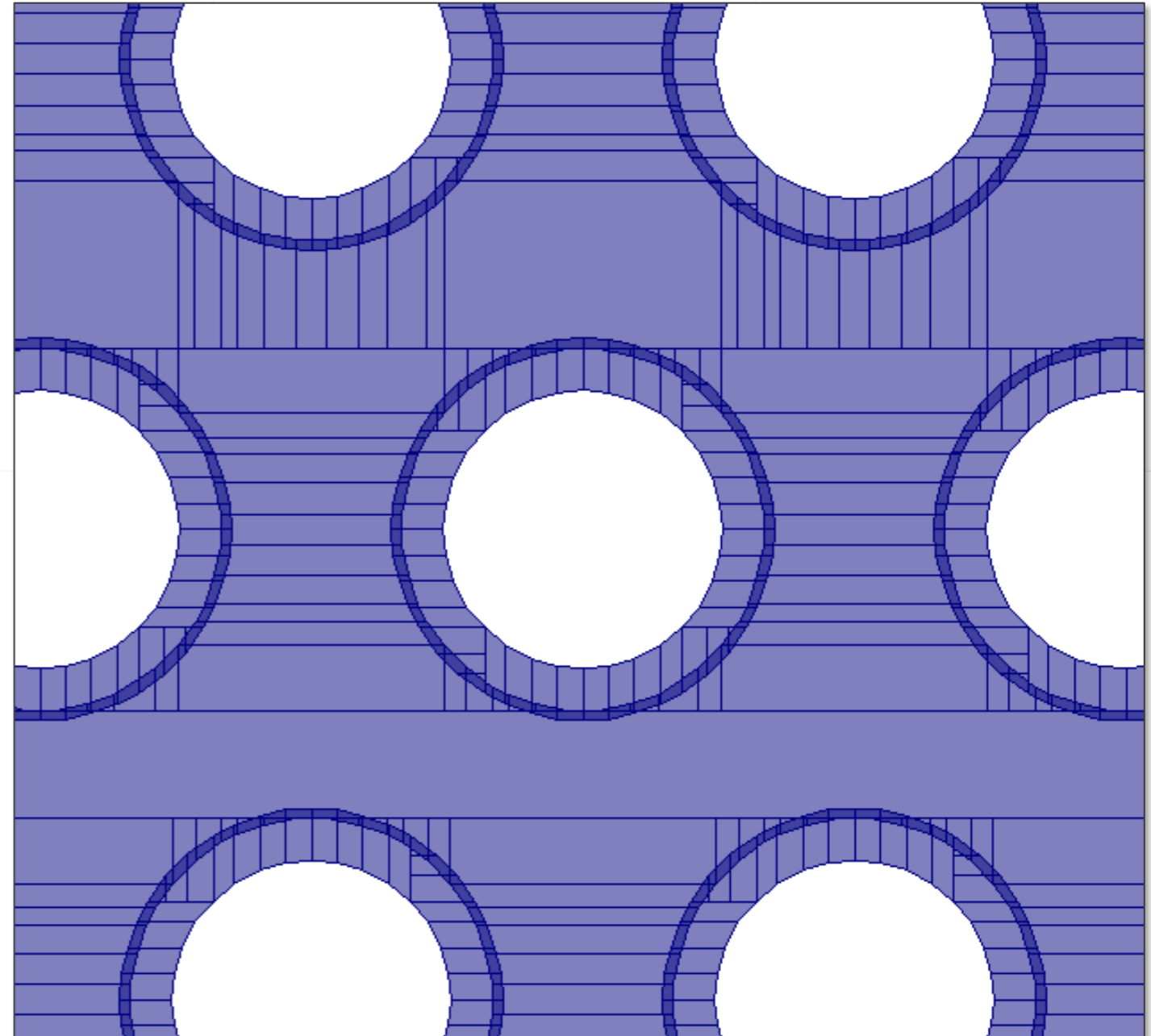

Thank You!

support@genisys-gmbh.com

Headquarters

GenISys GmbH
Eschenstr. 66
D-82024 Taufkirchen (Munich)
GERMANY

📞 +49-(0)89-3309197-60

📠 +49-(0)89-3309197-61

✉ info@genisys-gmbh.com

USA Office

GenISys Inc.
P.O. Box 410956
San Francisco, CA
94141-0956
USA

📞 +1 (408) 353-3951

✉ usa@genisys-gmbh.com

Japan / Asia Pacific Office

GenISys K.K.
German Industry Park
1-18-2 Hakusan Midori-ku
Yokohama 226-0006
JAPAN

📞 +81 (0)45-530-3306

📠 +81 (0)45-532-6933

✉ apsales@genisys-gmbh.com

